

יחידת פקאג' 20 טון

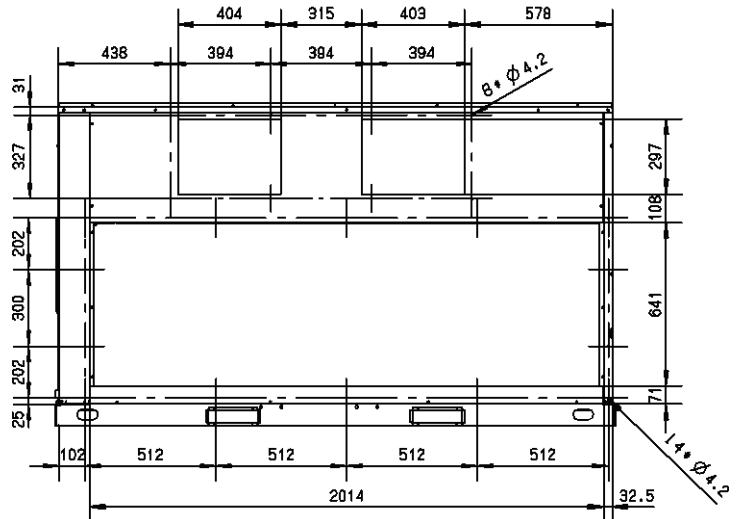

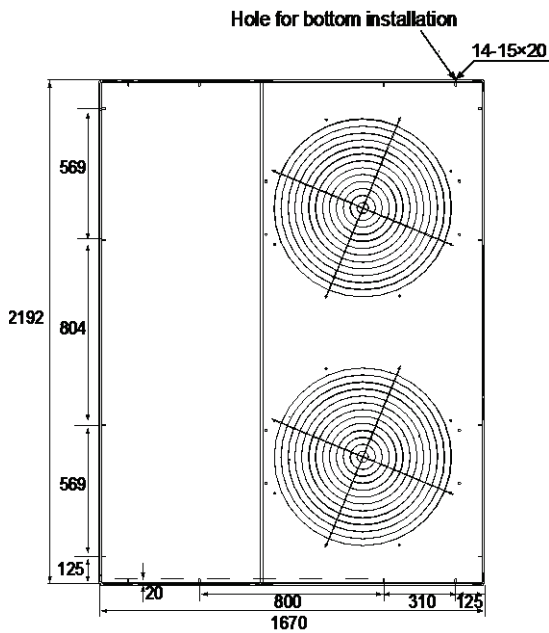
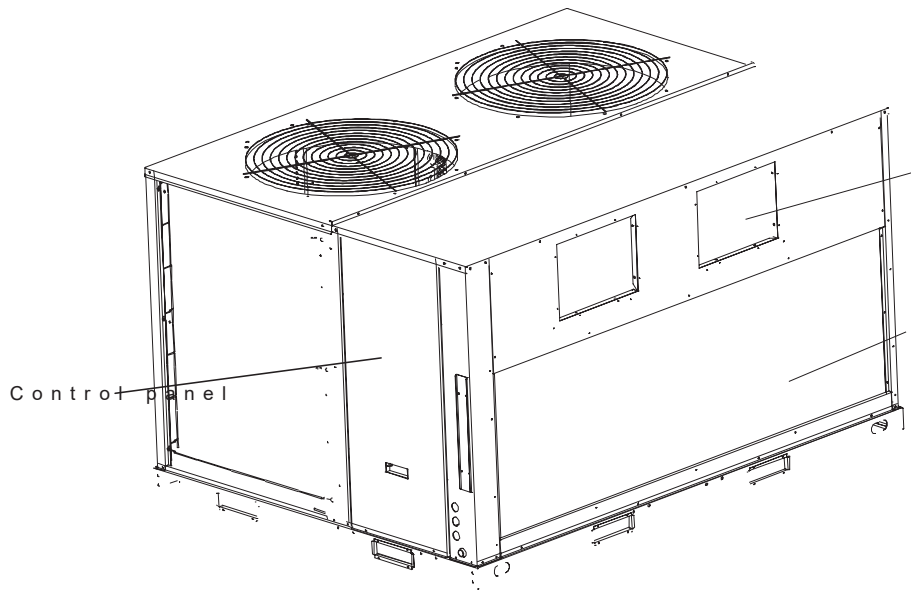
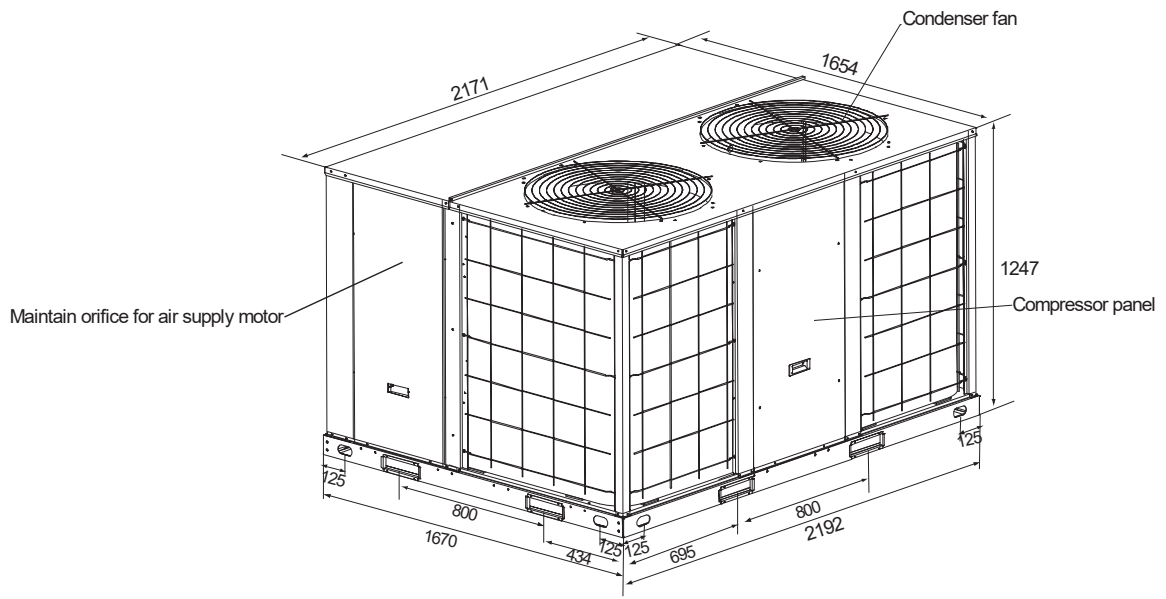

Nominal ton		(Ton)	20	
Model		MRC-200HWN1-R(C)		
Power Supply		V,Ph,Hz	380~415V,3Ph,50Hz	
Cooling	Cooling Capacity	Btu/h	240000	
		kW	70.0	
	Power Input	kW	22.6	
Heating	Heating Capacity	Btu/h	260000	
		kW	75	
	Power Input	kW	23.6	
Max. input consumption		kW	32.5	
Max. current		A	63.2	
Performance	Indoor fan air flow	CFM	8800	
	ESP	Pa	120	
	EER	Btu/h/W	10.6	
	COP	Btu/h/W	11	
Indoor Coil	Number of rows		4	
	Fin spacing	mm	1.3	
		FPI	20	
	Tube diameter	mm	7	
inch		9/32		
Indoor fan	Type		FC Centrifugal	
	Quantity		1	
	Drive type		Belt	
	Motors quantity		1	
	Motor model		YE2-132S-4-5.5KW	
Compressor	Type		Scroll	
	Quantity		2	
	Model		ZP144KCE-TFD-522×2	
	Brand		Copeland	
	Capacity	Btu/h	120500×2	
	Refrigerant oil charge	ml	3253x2	
Outdoor Coil	Number of rows		3	
	Fin spacing	mm	1.5	
		FPI	17	
	Tube diameter	mm	7	
inch		9/32		
Outdoor Fan	Type		Propeller	
	Quantity		2	
	Drive type		Direct	
	Motors quantity		2	
	Motor model		YS1100-6-3	
Refrigerant	Type		R410A	
	Refrigerant volume	kg	6.7+6.7	
	Refrigerant Control		Piston	
Net Weight		kg	690	
Gross Weight		kg	720	
Net Dimension	WxHxD	mm	2192x1247x1670	
Packing	WxHxD	mm	2212x1284x1695	
Shipping	Qty/Per 20'/40'/40'HQ		3/7/14	